

Caractéristiques techniques :

Type	Référence	Rotation [tr/min]	Voltage [V]	Puissance [kW]	IP	Pression acoustique		Débit maxi [m3/h]	Pression Maxi [Pa]	Poids [kg]
						1m*	5m*			
WPA-3-S-1-N	801W01	3000	230	0.37	54	78/70	64/56	1160	940	24
WPA-3-S-3-N	801W13	3000	3x400	0.37	54	78/70	64/56	1160	940	
WPA-5-S-1-N	801W02	3000	230	0.55	54	76/67	62/53	1900	1250	27
WPA-5-S-3-N	801W03	3000	3x400	0.55	54	76/67	62/53	1900	1250	
WPA-6-S-1-N	801W04	3000	230	0.75	54	83/75	69/61	2500	1700	32
WPA-6-S-3-N	801W05	3000	3x400	0.75	54	83/75	69/61	2500	1700	
WPA-7-S-1-N	801W06	3000	230	1.1	54	86/74	72/60	3100	1800	34
WPA-7-S-3-N	801W07	3000	3x400	1.1	54	86/74	72/60	3100	1800	
WPA-8-S-3-N	801W08	3000	3x400	1.5	54	88/78	74/64	3900	2050	44
WPA-9-S-3-N	801W09	3000	3x400	2.2	54	91/82	77/68	4500	2400	52
WPA-10-S-3-N	801W10	3000	3x400	3.0	54	91/87	77/67	6200	2450	65.5
WPA-11-S-3-N	801W11	3000	3x400	5.5	54	97/88	83/74	8050	2950	82
WPA-13-S-3-N	801W12	3000	3x400	7.5	54	99/90	85/76	10800	3300	104

*1^{ère} mesure : Ventilateur, aspiration et refoulement ouverts, 2^{ème} mesure : avec silencieux

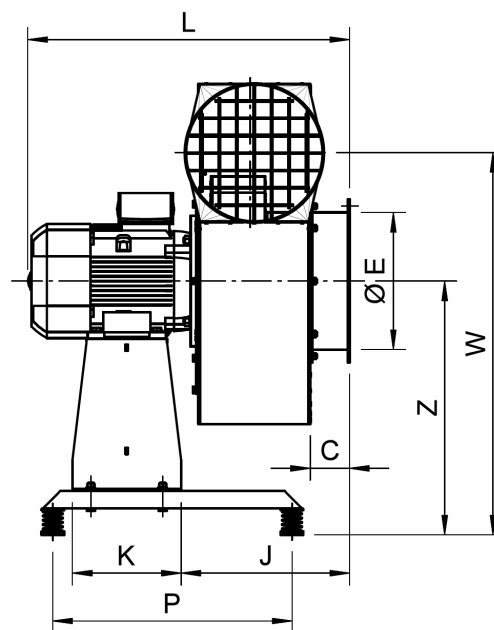
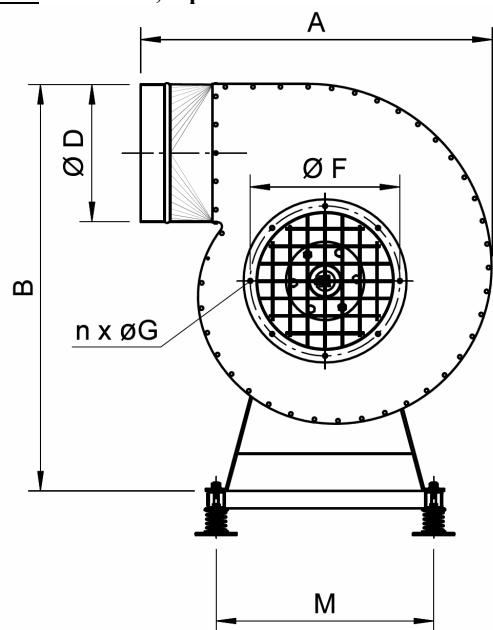

Dimensions

Type	A [mm]	B [mm]	C [mm]	W [mm]	Z [mm]	D [mm]	E [mm]	F [mm]	n [pc.]	G [mm]	M [mm]	P [mm]	K [mm]	J [mm]	L [mm]
WPA-3-S-1-N	415	520	50	555	405	125	125	155	6	7,0	345	400	200	170	400
WPA-3-S-3-N															
WPA-5-S-1-N	485	575	60	595	405	160	160	194	6	7,0	345	400	200	195	420
WPA-5-S-3-N															
WPA-6-S-1-N	500	600	60	620	410	160	160	194	6	7,0	345	400	200	205	445
WPA-6-S-3-N															
WPA-7-S-1-N	550	605	60	605	410	200	160	194	6	7,0	345	400	200	220	460
WPA-7-S-3-N															
WPA-8-S-3-N	570	685	60	685	480	200	200	224	8	9,0	425	450	220	215	490
								234							
								246							
WPA-9-S-3-N	615	730	60	725	480	200	200	224	8	9,0	425	450	220	215	510
								234							
								246							
WPA-10-S-3-N	655	810	80	780	550	250	250	274	8	9,0	500	550	250	325	650
WPA-11-S-3-N	675	830	80	805	565	250	250	274	8	9,0	500	550	250	335	665
WPA-13-S-3-N	805	940	90	880	585	315	315	344	8	9,0	500	550	250	390	735